

THIS DRAWING IS UNPUBLISHED. RELEASED FOR PUBLICATION
 © COPYRIGHT - By - ALL RIGHTS RESERVED.

LOC		DIST		REVISIONS			
P	LTR	DESCRIPTION		DATE	DWN	APVD	
GP	00	P2		REVISED PER ECO-12-011709	11MAR11	RW	SY

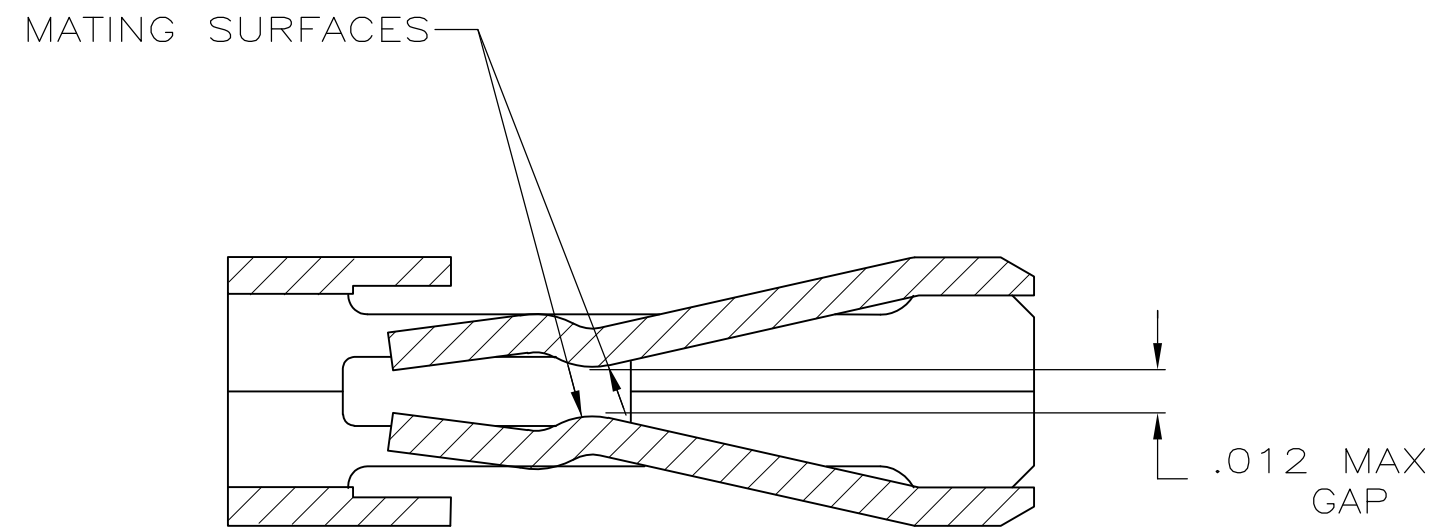

SECTION B-B
SCALE 20:1

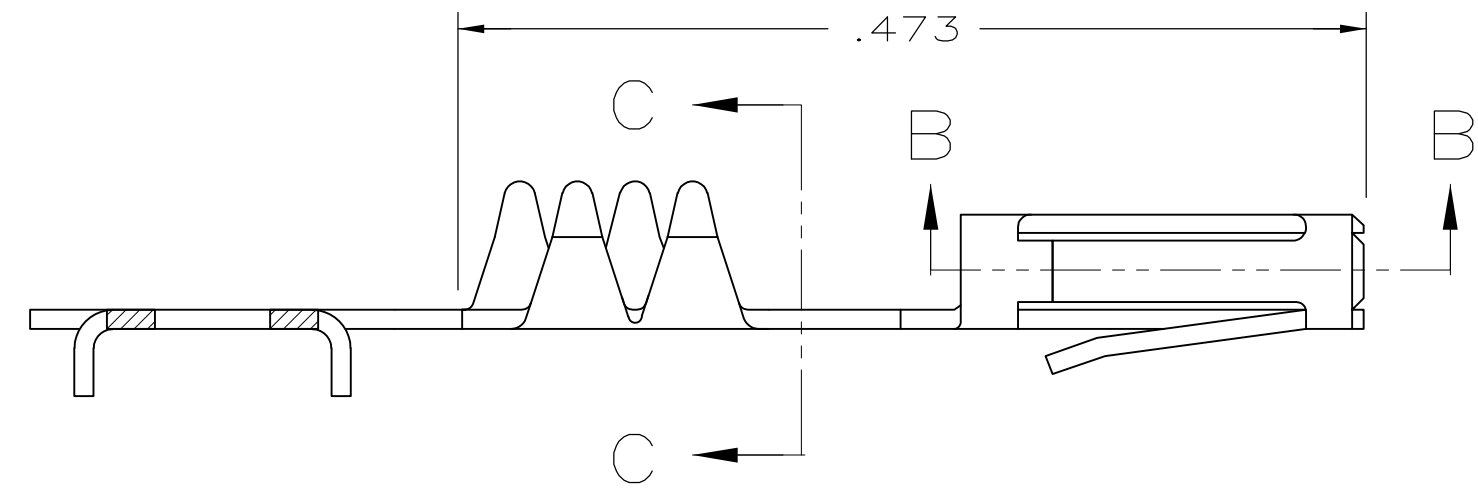
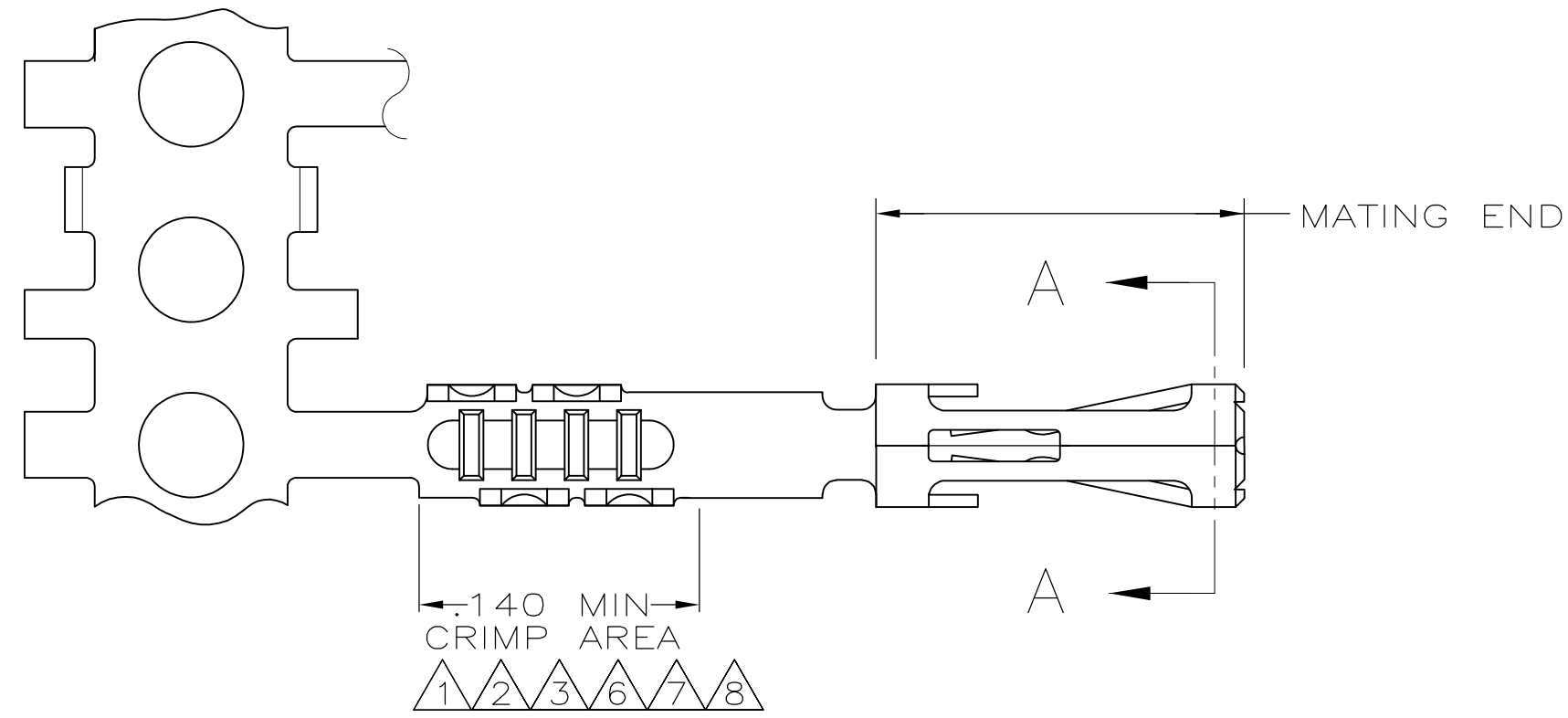
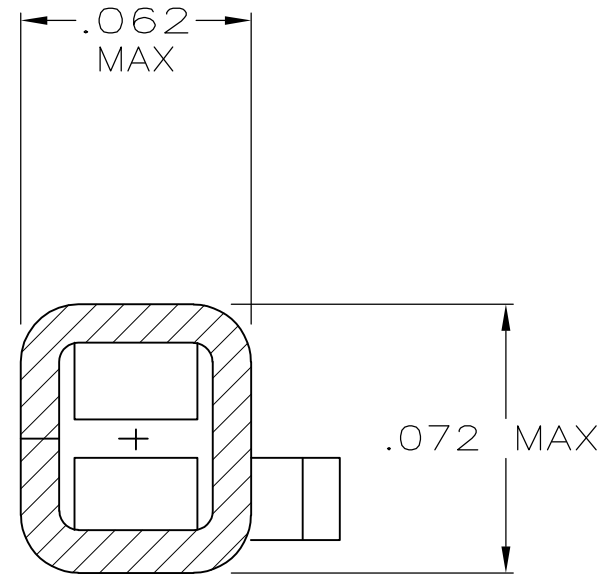

SECTION A-A
SCALE 20:1

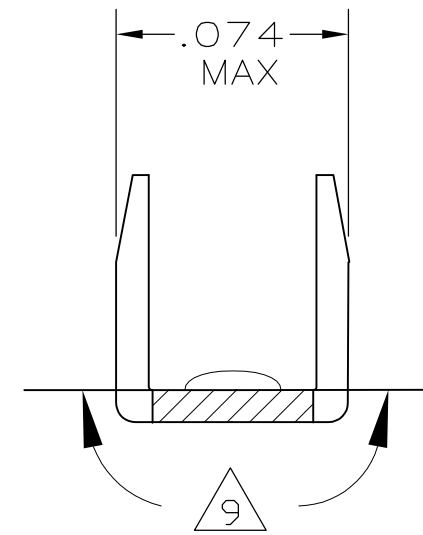

SECTION C-C
SCALE 20:1

- ① PREPLATED .000050 MIN THK NICKEL OVER ENTIRE CONTACT WITH .000015 MIN THK GOLD ON THE MATING SURFACES AND PLATED WITH .000100 MIN THK BRIGHT TIN/LEAD IN CRIMP AREA.
- ② PREPLATED .000050 MIN THK NICKEL OVER ENTIRE CONTACT WITH .000030 MIN THK GOLD ON THE MATING SURFACES AND PLATED WITH .000100 MIN THK BRIGHT TIN/LEAD IN CRIMP AREA.
- ③ PREPLATED .000050 MIN THK NICKEL OVER ENTIRE CONTACT WITH .000050 MIN THK GOLD ON THE MATING SURFACES AND PLATED WITH .000100 MIN THK BRIGHT TIN/LEAD IN CRIMP AREA.
- ④ .000100 MIN THK BRIGHT TIN/LEAD OVER .000050 MIN THK NICKEL OVER ENTIRE CONTACT.
- 5. MATING POST LENGTH ACCEPTED:
SINGLE ROW HOUSINGS .210-.323
DOUBLE ROW HOUSINGS .225-.323
- ⑥ GOLD FLASH IN CRIMP AREA, .000100 MIN TIN ON THE MATING END, BOTH OVER .000050 MIN NICKEL.
- ⑦ PREPLATED .000050 MIN THK NICKEL OVER ENTIRE CONTACT WITH .000015 MIN THK GOLD ON THE MATING SURFACES, AND PLATED WITH GOLD FLASH IN THE CRIMP AREA.
- ⑧ PREPLATED .000050 MIN THK NICKEL OVER ENTIRE CONTACT WITH .000030 MIN THK GOLD ON THE MATING SURFACES, AND PLATED WITH GOLD FLASH IN THE CRIMP AREA.
- ⑨ GOLD PLATING MAY OR MAY NOT BE PRESENT ON THE BOTTOM OF THE CRIMP BARREL IN THIS AREA.

	⑨ ⑧	1-487117-1
	⑨ ⑦	1-487117-0
	⑨ ⑥	487117-9
	④	487117-8
OBS	③	487117-6
	②	487117-5
	①	487117-4
	FINISH	PART NO

THIS DRAWING IS A CONTROLLED DOCUMENT.		DWN	G.A.MACK	8-30-83	TE TE Connectivity		
DIMENSIONS: INCHES		CHK	D.DOLLYHIGH	8-31-83			
TOLERANCES UNLESS OTHERWISE SPECIFIED:		APVD	-	-	RECEPTACLE CONTACT, HIGH PRESSURE		
0 PLC	± -	PRODUCT SPEC	108-9024	-			
1 PLC	± -	APPLICATION SPEC	114-16015	SIZE	CAGE CODE	DRAWING NO	RESTRICTED TO
2 PLC	± -	MATERIAL	PHOS BRONZE	A2	00779	C=487117	-
3 PLC	± .005	FINISH	SEE TABLE	SCALE	10:1	SHEET	1 of 1
4 PLC	± -	CUSTOMER DRAWING		REV	P2		
ANGLES	± -						